

**Report of the DOE
Quantum Internet
Blueprint Workshop**

**From Long-distance Entanglement to
Building a Nationwide Quantum Internet**

February 5-6, 2020

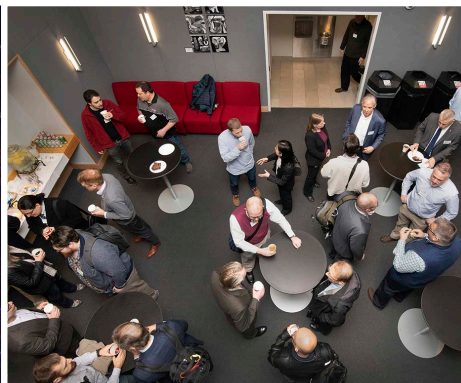

A Quantum Path Forward

Today, many scientific experts recognize that building and scaling quantum-protected and enhanced communication networks are among the most important technological frontiers of the 21st century. The international research community perceives the construction of a first prototype global quantum network—the Quantum Internet—to be within reach over the next decade.

In February 2020, the U.S. Department of Energy (DOE)'s Office of Advanced Scientific Computing Research hosted the Quantum Internet Blueprint workshop to define a potential roadmap toward building the first nationwide quantum Internet. The workshop participants included representatives from DOE national laboratories, universities, industry, and other U.S. agencies with serious interests in quantum networking. The goal was to provide an outline of the essential research needed, detail any engineering and design barriers, and suggest a path forward to move from today's limited local network experiments to a viable, secure quantum Internet.

**Report of the
DOE Quantum Internet
Blueprint Workshop**

February 5-6, 2020

SUNY Global Center, New York, NY

Workshop Chairs

Kerstin Kleese van Dam, Brookhaven National Laboratory
Inder Monga, Energy Sciences Network
Nicholas Peters, Oak Ridge National Laboratory
Thomas Schenkel, Lawrence Berkeley National Laboratory

Organizing Committee

Gabriella Carini, Brookhaven National Laboratory
Supratik Guha, Argonne National Laboratory
Joseph Lykken, Fermilab

Sponsored by:

U.S. Department of Energy, Office of Science, Office of
Advanced Scientific Computing Research
Contact: Barbara Helland, Associate Director, Office of
Advanced Scientific Computing Research



Acronyms

ASCR	Advanced Scientific Computing Research
BES	Basic Energy Sciences
CEWIT	Center of Excellence in Wireless and Information Technology
DOE	U.S. Department of Energy
DWDM	dense wavelength division multiplexing
EPS	entangled photon source(s)
ESnet	Energy Sciences Network
FPGA	field-programmable gate array(s)
HPC	high-performance computing
IEQNET	Illinois-Express Quantum Network
MANLAN	Manhattan Landing
NASA	National Aeronautics and Space Administration
NISQ	noisy intermediate-scale quantum
NSF	National Science Foundation
PRD	Priority Research Direction(s)
Q-nodes	quantum nodes
QCC	Quantum Computing Chip(s)
QIS	Quantum Information Science
QIT	Quantum Information Technology
Q-LAN	quantum local area network(s)
SBU	Stony Brook University
SDN	software-defined networking
telecom	telecommunications

Table of Contents



- I. Introduction 10
 - I.1. Overview of Future Scientific Application Areas 11

- 2. Priority Research Directions..... 14
 - 2.1. PRD 1: Provide the Foundational Building Blocks for a Quantum Internet 14
 - 2.2. PRD 2: Integrate Multiple Quantum Networking Devices 15
 - 2.3. PRD 3: Create Repeating, Switching, and Routing for Quantum Entanglement 15
 - 2.4. PRD 4: Enable Error Correction of Quantum Networking Functions 17

- 3. Blueprint Roadmap Milestones..... 20
 - 3.1. Milestone 1: Verification of Secure Quantum Protocols over Fiber Networks 20
 - 3.2. Milestone 2: Inter-campus and Intra-city Entanglement Distribution 21
 - 3.3. Milestone 3: Intercity Quantum Communication using Entanglement Swapping 21
 - 3.4. Milestone 4: Interstate Quantum Entanglement Distribution using Quantum Repeaters 22
 - 3.5. Milestone 5: Build a Multi-institutional Ecosystem between Laboratories, Academia,
and Industry to Transition from Demonstration to Operational Infrastructure 24

- 4. Workshop Report Authors..... 27

- 5. Workshop Observers..... 30

- 6. References..... 32

Figures and Tables

Table 2:1. Comparison of a TCP/IP 5-layer Reference Model with a proposed Quantum Internet Network Architecture 14

Figure 2:1. Concept of a cascaded quantum network prototype using classical network control interacting with nodes equipped with quantum hardware. Reproduced from "Proc. SPIE 9873, Quantum Information and Computation IX," 98730B (2016)..... 15

Figure 2:2. Quantum path and routing of entangled photons using SDNs using the Chicago quantum network..... 15

Figure 2:3. Example of a one-hop, first-generation quantum repeater. Two sources generate independent entangled pairs A-B and C-D. One member of each pair, B and C, are brought together and interfered at an intermediate location, projecting the B-C pair onto one of four Bell states (Bell state measurement). This partial collapse of the four-particle wavefunction results in the two remaining particles, A and D, being in an entangled state, separated by a long distance. 16

Figure 2:4. Example of a second-generation quantum repeater network in a non-trivial topology, using memory-assisted quantum repeaters, quantum switches/routers, and error-corrected entanglement swapping measurements. Entangled photon pairs are transmitted continually from sources (yellow hexagon) along quantum fiber channels (red lines) to Bell receiver nodes (green circles), where they are captured and stored in quantum memories (blue cylinders). When users at two of the nodes, for example, A and B in the diagram, demand an entangled pair, multiple hops of entanglement swapping can be used to produce an entanglement connection between already-existing photons stored at A and B's nodes by carrying out Bell state measurements (purple diamond) on already-existing photons stored in intermediate nodes. 17

Figure 3:1. Design schematic for a three-node quantum network with SDN controller connected to both the classical and quantum switch. Reproduced from "Proc. SPIE 9873, Quantum Information and Computation IX," 98730B (2016). 20

Figure 3:2. IEQNET Topology 21

Figure 3:3. Long Island quantum network extended to New York City. The network will use a chain of quantum repeaters, extended across Long Island via three entangled sources, six quantum memories, and two entanglement swapping stations. Using ESnet's existing fiber infrastructure, the network will connect SBU to New York City via Brookhaven Lab with intermediate stations on the two campuses and in Garden City, N.Y. This is expected to be the first quantum repeater network of its kind in the world. 22

Figure 3:4. Schematic diagram of a quantum network, where quantum channels are used alongside classical communication channels. 23

Report of the DOE Quantum Internet Blueprint Workshop



I. Introduction

Quantum information science (QIS) concerns the study, control, and manipulation of quantum systems with the goal of achieving information sensing, processing, and communication beyond the limits of the classical world. While QIS has been studied for several decades (Richard Feynman first proposed the idea in 1981), the last five years have brought tremendous progress and breakthroughs, igniting a new dawn for this research field. As traditional computing systems struggle to increase their computational power in line with demand (Moore 2019), a growing number of research institutions and industry have turned their focus onto quantum technologies. Progressively powerful quantum computing systems are being developed today, such as IBM's 53-qubit quantum computer (Hruska 2019), announced in September 2019. Meanwhile, in October 2019, Google proclaimed "quantum supremacy" (Arute et al. 2019). Researchers are on the hunt for applications that can leverage current "noisy intermediate-scale quantum" (NISQ)-era machines to advance scientific research (Brooks 2019), and industry's early adopters similarly are exploring how to leverage these new, still imperfect capabilities.

While quantum computing has garnered most of the recent headlines, quantum networking—especially with its promise of secure communication—actually is capturing the interest of a growing community across science, industry, and national security. Today, many people recognize that building and scaling quantum-protected and enhanced communication networks are among the most important technological frontiers of the 21st century. Although a general-purpose quantum computer still is many years away, the research community perceives a quantum Internet may be closer to realization. Since 2017, China, a long-time investor in QIS, has been breaking distance records for quantum networks. In June 2019, they established satellite-enabled photon entanglement over a distance of 1200 km (Messier 2019). Europe formed the Quantum Internet Alliance to develop the first blueprint for a quantum Internet (<http://quantum-internet.team/>). Since then, they have pursued a variety of experiments to validate their ideas, including demonstrating entanglement over 50 km via optical fiber in January 2019 (Krutianskiy et al. 2019). In April 2019, scientists from the U.S. Department of Energy (DOE)'s Brookhaven National Laboratory, Stony Brook University (SBU), and DOE's Energy Sciences Network (ESnet) achieved long-distance entanglement over 18 km using unique portable quantum entanglement sources and an existing DOE ESnet communications fiber network (Plata 2019). One aspect that sets this work apart is the entanglement sources are portable and can be easily mounted in standard data center computer server racks that are connected to regular fiber distribution panels. Since that initial work, SBU and Brookhaven Lab have established an 80-mile quantum network testbed. Argonne National Laboratory has created a 52-mile quantum loop entanglement distribution network that will be connected to Fermilab, establishing a three-node, 80-mile testbed for quantum communication.

Recent U.S.-based workshops also have honed in on critical research challenges elemental to creating a quantum Internet, such as *Transduction from the Opportunities for Basic Research for Next-Generation Quantum Systems* workshop, organized in October 2017 by the DOE's Basic Energy Sciences (BES) office (U.S. Department of Energy, Office of Basic Energy Sciences 2017); *Quantum Repeaters in the Quantum Networks for Open Science* workshop, organized in September 2018 by DOE's Office of Advanced Scientific Computing Research (ASCR) (U.S. Department of Energy, Office for Advanced Scientific Computing Research 2018); and the U.S. National Science Foundation (NSF)-supported *Development of Quantum InterConnects for Next-Generation Information Technologies* workshop, held Oct. 31-Nov. 01, 2019 (Awschalom et al. 2019). Traditionally, DOE has provided leadership in high-performance computing (HPC) and networking in support of open science. Quantum networking is a new and exciting technology poised to revolutionize how information gets transmitted between quantum systems and over long distances. However, it also is envisaged to have a major impact on large-scale sensing experiments, making this new technology of key interest to DOE mission areas, such as astronomy, materials discovery, and life sciences. While DOE already has been conducting research in the overall quantum network arena, it now has reached the point where it can consider moving from small-scale experiments toward a first nationwide quantum Internet facility.

Achieving the goal of elevating current U.S. QIS research, particularly related to a viable quantum Internet, to the level of worldwide leadership will require a multidisciplinary and multi-institutional team. This team must tackle the fundamental problem of defining and implementing a new model of the Internet stack adapted to entanglement-based quantum networks. To kick start the process, DOE's Office of Science organized the *Quantum Internet Blueprint Workshop* to explore the specific research and engineering advances needed to build a nationwide quantum Internet in the near term.

In February 2020, DOE-ASCR hosted the aforementioned Quantum Internet Blueprint Workshop, where representatives from DOE national laboratories, universities, industry, and other U.S. agencies with serious interests in quantum networking defined a potential roadmap toward building the first nationwide quantum Internet. This resulting report identifies key **Scientific Application Areas**, four **Priority Research Directions** (PRDs) and outlines five **Key Milestones** that must be achieved to facilitate an eventual national quantum Internet.

I.I. Overview of Future Scientific Application Areas

Recent U.S.-based workshops, such as *Opportunities for Basic Research for Next-Generation Quantum Systems* (U.S. Department of Energy, Office of Basic Energy Sciences 2017); *Quantum Networks for Open Science* (U.S. Department of Energy, Office for Advanced Scientific Computing Research 2018); and *Next-Generation Information Technologies* (Awschalom et al. 2019), have published a clear set of near-term applications for quantum networking technology, chiefly among them:

- **Sensor Networks.** *Networks of Quantum Clocks* are a commonly considered application, creating a network that could significantly improve the precision of measurements of certain phenomena, such as gravitational waves. *Networks of Quantum Enabled Telescopes* also could be linked to sharpen and enhance the aggregate images. Meanwhile, *Quantum Metrology* can enable more precise imaging technologies, such as microscopy (Ono, Okamoto, and Takeuchi 2013) or optical and electromagnetic imaging.
- **Upscaling Quantum Computing.** *Quantum Networking* could be used to connect to quantum computing systems, providing access without challenging “transitions” between classical and quantum systems. *Distributed Quantum Computing* links many smaller quantum computers through a quantum network. The resulting distributed quantum computing system provides computing capacity at a scale currently impossible to achieve in a single quantum computer.
- **Secure Quantum Communication.** The quantum Internet’s ability to deliver the ultimate in secure communication would be a central application. While *Quantum Key Distribution* currently is the main research focus that underpins secure quantum communication, it is the information exchange over a quantum channel—with its ability to detect any interception—that offers the ultimate in secure communication. Early adopters for such future solutions will be found in areas such as national security, banking, and energy delivery infrastructure. Other application areas may include health services, security for government services (e.g., elections), and gaming. *Blind Quantum Computing* is a specialized secure-communication-based service that enables protected task delegation to powerful quantum computers in the cloud (Fitzsimons 2017).

While many of these applications are envisioned for fiber-based quantum networks, these links pose the challenge of loss that grows exponentially with link distance, necessitating the need for a *quantum repeater* infrastructure. Alternatively, *free-space links* present transmission that decays only quadratically (due to diffraction), allowing significant quantum transmission over distances impossible for repeater-less fibers. For example, the recent satellite entanglement distribution demonstration achieved rates estimated to be 12 orders of magnitude above what a comparable fiber link would allow (J. Yin, Cao, Li, Liao, et al. 2017). Therefore, it is not unlikely that satellites or other free-space links could enable a critical “entanglement bridge” between local fiber-based quantum networks, affording a much sooner realization of, e.g., transcontinental and transatlantic quantum networks (Simon 2017; Oberhaus 2020).

Priority Research Directions



2. Priority Research Directions

Designing a quantum internet prototype capable of performing the aforementioned tasks will require developing a new quantum-updated version of the network stack (Table 2:I). Analogous to classical networking, the lowest element of this new stack will be the physical layer, including all quantum hardware devices and optical fibers. The hardware at the physical layer will be responsible for quantum information generation, timing, and synchronization. The data link layer will be tasked to run the physical layer, making attempts to produce entanglement between controllable quantum nodes. Requests can be made by higher layers to the link layer to produce entanglement. The network layer will be responsible for producing long-distance entanglement between nodes that are not directly connected, which is achieved by means of entanglement swapping using the link layer to generate entanglement between neighboring controllable nodes. The transport layer will be responsible for transmitting qubits deterministically using teleportation. The application layer will enable applications to use both classical and quantum network capabilities. These applications include entangling qubits of distant quantum computers or data transfers.

Table 2:I. Comparison of a TCP/IP 5-layer Reference Model with a proposed Quantum Internet Network Architecture

Application	Distributed Quantum Algorithms	
Transport	Coexistence with Classical Networks	Control Plane
Network	Entanglement Generation and Memory-assisted Distribution	
Data Link	Transduction Superconducting/Photonic	
Physical	Quantum Processor/Quantum Computer	
TCP/IP Network Stack	Entanglement Distribution Network Stack	

2.1. PRD I: Provide the Foundational Building Blocks for a Quantum Internet

Key Question: What are the key building blocks of a quantum Internet, and what performance parameters do they need to satisfy?

Today's quantum networking experiments rely on a set of devices with limited functionality and performance. However, it can be inferred from classical networks that to create wide-area, operational quantum networks, more capable devices with additional functionality are needed. These new devices must satisfy suitable requirements for reliability, scalability, and maintenance. Essential network devices likely will include quantum memory with efficient optical interface and satellite-to-fiber connections; high-speed, low-loss quantum switches; multiplexing technologies; and transducers for quantum sources and improved sources themselves, as well as transduction from optical and telecommunications regimes to quantum computer-relevant domains, including microwaves.

The National Science and Technology Council Subcommittee on Quantum Information Science recommended pursuing the following quantum networking technologies (extracted from *A Strategic Vision for America's Quantum Networks*¹):

- Quantum-limited detectors, ultra-low loss optical channels, space-to-ground connections, and classical networking and cybersecurity protocols.
- Entanglement and hyper-entangled state sources and transmission, control, and measurement of quantum states.
- Transducers for quantum sources and signals from optical and telecommunications (telecom) regimes to quantum computer-relevant domains, including microwaves.
- Development of quantum memory buffers and small-scale quantum computers that are compatible with photon-based quantum bits in the optical or telecom wavelengths.
- Long-range entanglement distribution (terrestrial and space-based) using quantum repeaters, allowing entanglement-based protocols between small- and large-scale quantum processors.

Other novel approaches likely will emerge over time.

¹ <https://www.whitehouse.gov/wp-content/uploads/2017/12/A-Strategic-Vision-for-Americas-Quantum-Networks-Feb-2020.pdf>.

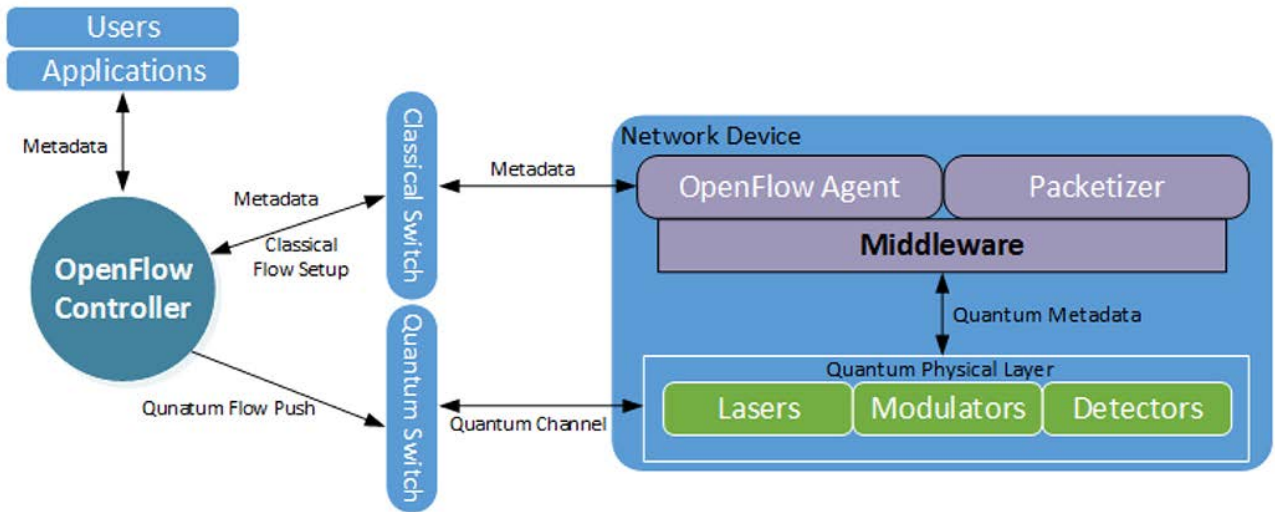

Figure 2:1. Concept of a cascaded quantum network prototype using classical network control interacting with nodes equipped with quantum hardware. Reproduced from "Proc. SPIE 9873, Quantum Information and Computation IX," 98730B (2016).

2.2. PRD 2: Integrate Multiple Quantum Networking Devices

Key Question: How will physical barriers to integrating multiple quantum network devices into high-performance quantum Internet components be overcome?

Generally, key quantum network components available today remain at a laboratory-level readiness and have yet to run operationally in a full network configuration. Moving forward will require overcoming critical challenges aimed to achieve cascaded operation and connectivity, among them:

- Integrating existing components by unifying their operational properties (bandwidth, wavelength, duty-cycle) using systems-level engineering.
- Achieving high-rate (GHz) quantum entanglement sources, quantum memory buffers, and detectors to compensate for cascading operation losses (Figure 2:1).
- Further development of key quantum network components, such as high-speed, low-loss quantum switches and multiplexing technologies.

2.3. PRD 3: Create Repeating, Switching, and Routing for Quantum Entanglement

Key Question: How can fundamental network functions for a nationwide quantum Internet be created?

Multi-hop networks require a means of strengthening and repeating signals along with selecting paths through the network. While physical and software solutions are used in classical networks, an equivalent has not been found for quantum networks. Challenges include different forms of quantum entanglement generation, swapping, and purification protocols over multiple users, as well as coordination and integration of traditional networks with quantum network technologies for optimal control and operations.

Routing is a fundamental network function. Multi-hop networks require a means of selecting paths through the network. First prototypes of the entanglement-based quantum network will not use quantum memory and

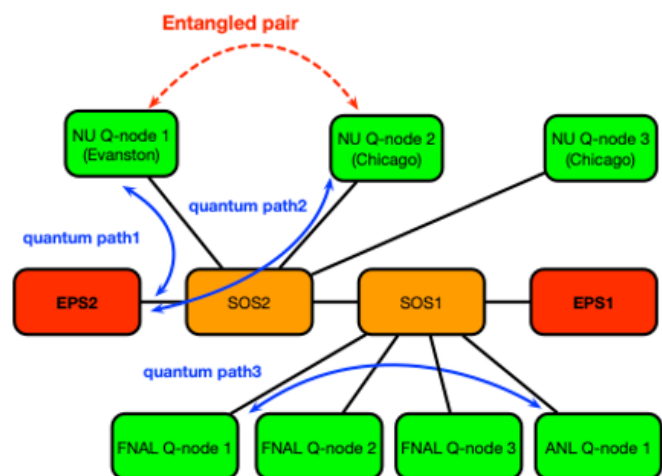

Figure 2:2. Quantum path and routing of entangled photons using SDNs using the Chicago quantum network.

repeaters. Instead, they will employ software-defined-network (SDN) technology to perform traditional wavelength routing and assignment in optical networks to establish quantum paths among quantum nodes or between quantum nodes and entangled photon sources (EPS) (Figure 2:2). Optical switches will be dynamically programmed to establish multiple quantum paths. These non-trivial topologies will allow for establishing entanglement distribution and quantum teleportation protocols over multiple users. Coexistence with traditional networks in the same optical fiber transmission systems will be critical for sharing the same dense wavelength division multiplexing (DWDM) network component.

To move from simple forms of entanglement distribution between a fixed pair of destinations (limited by the attenuation of single-photon telecom fibers to distances on the order of ~100 km or less), it is necessary to extend the entanglement pair distribution range using quantum repeaters. Unlike the operation of a classical repeater, the quantum repeater does not amplify photons in an entangled state while they are transiting. Instead, the quantum repeater can "hop" the entanglement property across an additional distance interval by consuming the resource of a second entangled pair. The innovation needed to fulfill this is the quantum process of *entanglement swapping*.

The potential for improved distance transmission with a quantum repeater is realized with the addition of working quantum memories, which can buffer a pair of photons after a successful transmission without requiring the other pair's survival at exactly the same time. A prototype of a one-hop quantum repeater requires four heralded quantum memories (Figure 2:3). The probability of the whole entanglement swapping procedure succeeding then requires two successful pair transmissions and storage occurring within the memory's storage time, resulting in a much higher order than coincident success in a single test interval and allowing for higher distribution rates of entanglement covering longer distances. Other approaches to quantum repeaters rely on all-optical quantum processing (Pant et al. 2017; Hasegawa et al. 2019), as well as those based on atomic ensembles (Sangouard et al. 2011).

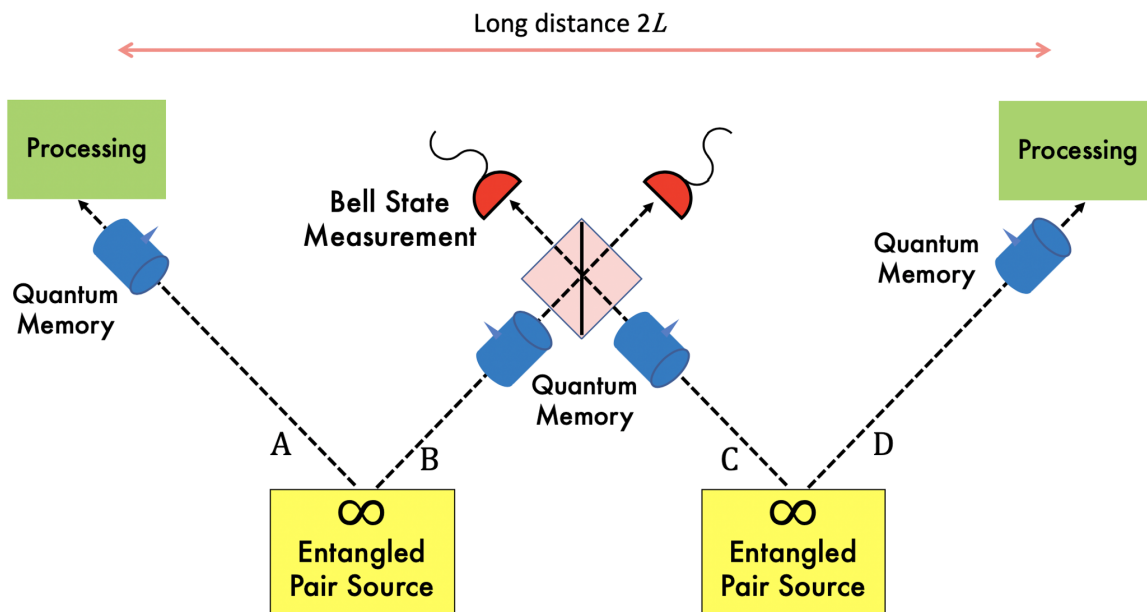

Figure 2:3. Example of a one-hop, first-generation quantum repeater. Two sources generate independent entangled pairs A-B and C-D. One member of each pair, B and C, are brought together and interfered at an intermediate location, projecting the B-C pair onto one of four Bell states (Bell state measurement). This partial collapse of the four-particle wavefunction results in the two remaining particles, A and D, being in an entangled state, separated by a long distance.

2.4. PRD 4: Enable Error Correction of Quantum Networking Functions

Key Question: How can fault tolerant network functions be achieved?

A fundamental difference for quantum networks arises from the fact that entanglement, whose long-distance generation is an essential network function, is inherently present at the network's physical layer. This differs from classical networking, where shared states typically are established only at higher layers. In this context, solutions must be found to guarantee network device fidelity levels capable of supporting entanglement distribution and deterministic teleportation, as well as quantum repeater schemes that can compensate for loss and allow for operation error correction.

The last step in the evolution of quantum communication networks will be reached when devices capable of error correction and concatenated quantum repeaters are available (Figure 2:4). This quantum network stage would be able to support all protocols required for distributed quantum computing and quantum sensor applications, including distributed memory many-computer architectures and their applications. Realizing such a quantum network will require a number of advances in quantum network technology, including quantum links with high repetition rates, fidelity capable of supporting entanglement distribution and deterministic teleportation, and quantum repeater schemes that allow for both loss and operation error correction and can support the necessary operation depth at each node (which have to be performed fault tolerantly). The ability to generate multipartite entanglement also is especially relevant for sensing applications.

A common requirement for all of these applications, especially those requiring a higher level of network functionality, is the need for developing an architecture and defining a quantum network stack (as defined in Table 2:1). The architecture should allow the quantum protocols to connect to the underlying hardware implementation transparently and provide the necessary functionality to counteract the effects of limited qubit and gate lifetimes.

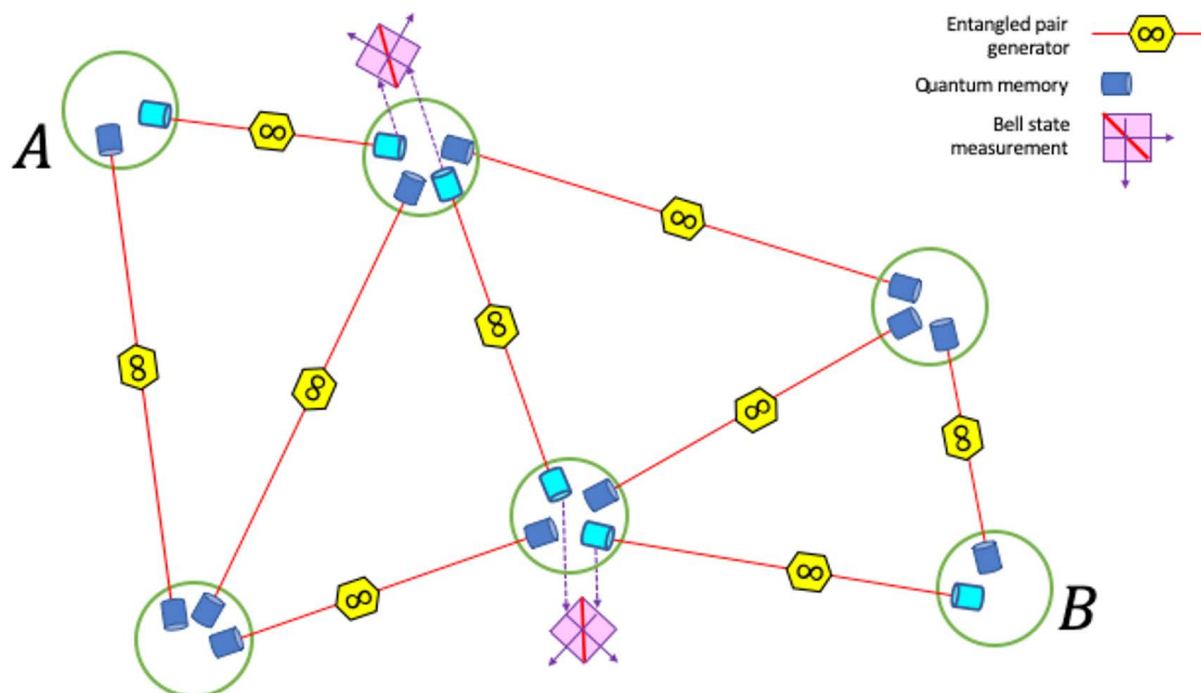
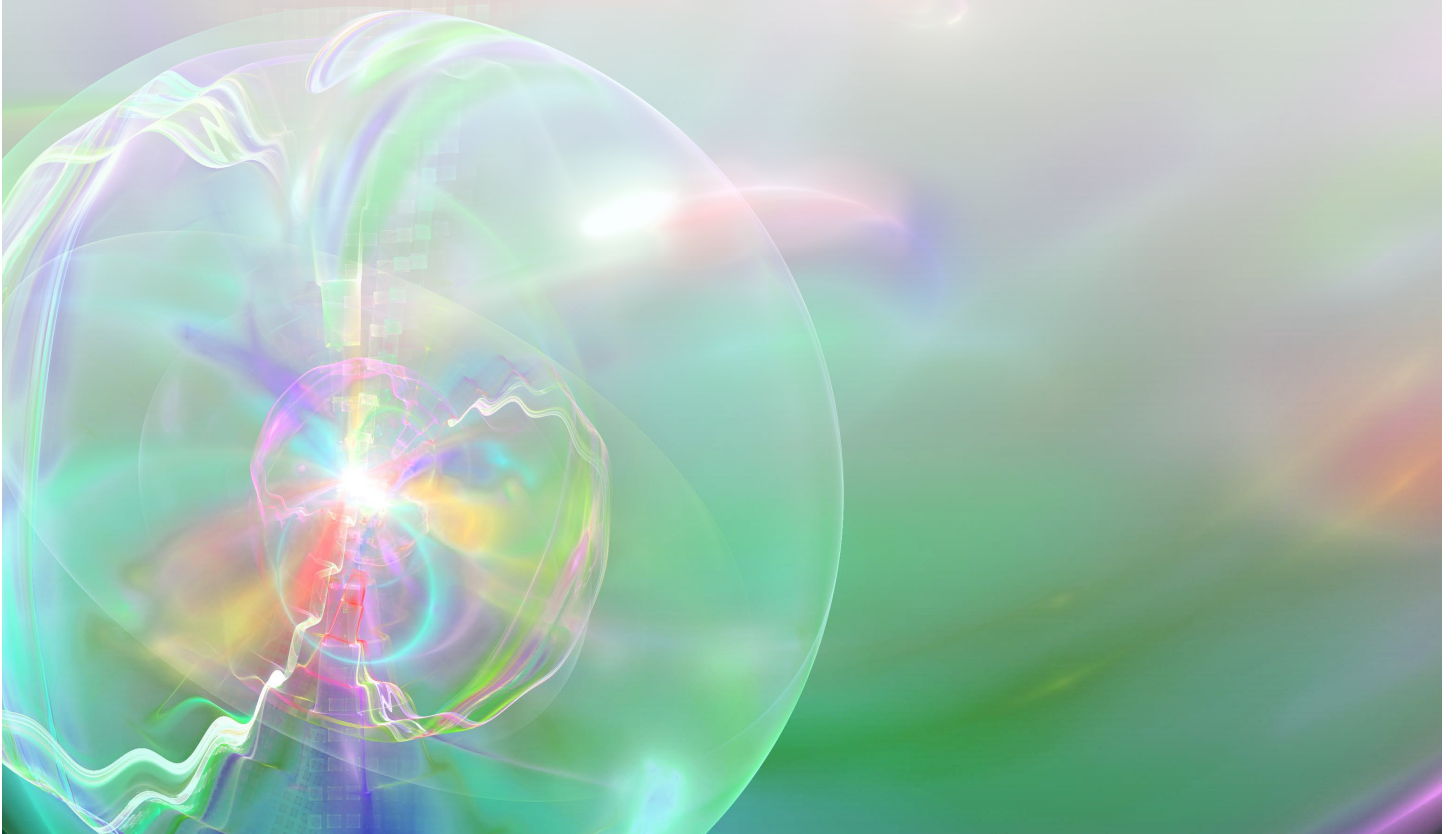

Figure 2:4. Example of a second-generation quantum repeater network in a non-trivial topology, using memory-assisted quantum repeaters, quantum switches/routers, and error-corrected entanglement swapping measurements. Entangled photon pairs are transmitted continually from sources (yellow hexagon) along quantum fiber channels (red lines) to Bell receiver nodes (green circles), where they are captured and stored in quantum memories (blue cylinders). When users at two of the nodes, for example, A and B in the diagram, demand an entangled pair, multiple hops of entanglement swapping can be used to produce an entanglement connection between already-existing photons stored at A and B's nodes by carrying out Bell state measurements (purple diamond) on already-existing photons stored in intermediate nodes.

Blueprint Roadmap Milestones



3. Blueprint Roadmap Milestones

The workshop further suggested a set of five key milestones to mark progress along the route to building the first nationwide quantum Internet, utilizing the outcomes of the already defined PRDs as they become available.

When fully deployed, the quantum Internet will connect any two points (eventually on the planet) via quantum communications through a system of national quantum networks. Each quantum network will interconnect nodes based on a heterogeneous set of technologies that will enable the realization of a diverse set of quantum protocols, such as multi-party secure communications, sensing, blind quantum computing, and distributed quantum computing. To date, no quantum Internet exists. Nevertheless, there already are a number of useful components and testbeds available that can inform the design of a first-generation quantum Internet. The following sections describe a number of existing and near-term technologies and quantum network testbeds, followed by an outline of required steps to refine a quantum Internet architecture and identify a clear roadmap to building a quantum Internet. Ordered by their level of complexity, each higher stage is assumed to incorporate the functionality of the previous stages.

3.1. Milestone I: Verification of Secure Quantum Protocols over Fiber Networks

Prepare and measure quantum networks. In this quantum network prototype, end users receive and measure quantum states, but entanglement is not necessarily involved. Applications to be achieved in this kind of network include exchanges between non-trusted nodes with (comparatively) higher tolerance on timing fluctuations, qubit loss, and errors.

Users can have their password verified without revealing it, and two end users can share a private key known only to them. The requirements for applications implementing this quantum network stage include:

- End-to-end quantum functionality for their operations.
- Transmission and measurement that can be post selected.
- Qubits that are immediately measured to produce classical correlations.

An example of this network has been demonstrated in the Chattanooga, Tenn., area (effort led by Oak Ridge and Los Alamos national laboratories) using a combination of quantum cryptography systems, connected via trusted nodes (Figure 3:1). An application domain of interest is the protection of critical infrastructures through secure communication, e.g., within the electrical power grid.

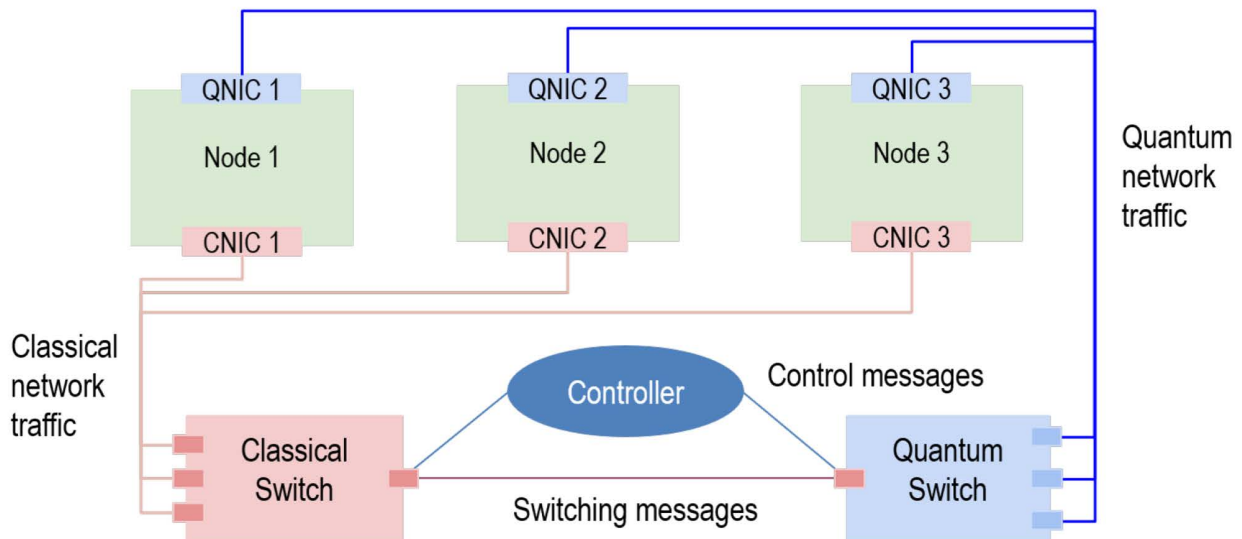

Figure 3:1. Design schematic for a three-node quantum network with SDN controller connected to both the classical and quantum switch. Reproduced from "Proc. SPIE 9873, Quantum Information and Computation IX," 98730B (2016).

3.2. Milestone 2: Inter-campus and Intra-city Entanglement Distribution

Entanglement distribution networks. In this type of quantum network, any two end users can obtain entangled states, requiring end-to-end creation of quantum entanglement in a deterministic or heralded fashion, as well as local measurements. These networks provide capabilities by enabling the implementation of device-independent protocols, such as measurement device-independent quantum key distribution and two-party cryptography. The tolerance for fluctuations, loss, and errors is lower than the previous class (Milestone I). Initial integrations of classic and quantum networks exist.

One example, the Illinois-Express Quantum Network, or IEQNET, (shown in Figure 3:2) comprises multiple sites that are geographically dispersed in the Chicago metropolitan area. These sites include Northwestern University (NU); StarLight, a Northwestern communications exchange site at 750 N. Lakeshore Drive, Chicago; Fermilab (FNAL); and Argonne (ANL). Each site has one or multiple quantum nodes (i.e., Q-nodes) that can perform quantum communication and measurement. Q-nodes are connected to SDN-enabled optical switches through optical fibers. The optical

switches are further connected among one another to form a meshed all-optical network. IEQNET currently contains two logically independent quantum local area networks (Q-LANs): Q-LAN1 and Q-LAN2 with plans to evolve the ANL site to Q-LAN3. The Q-LANs are connected by dedicated communication channels established in ESnet or by additional dark fibers between Fermilab and StarLight.

Immediate application areas for such networks would be small-scale sensor networks.

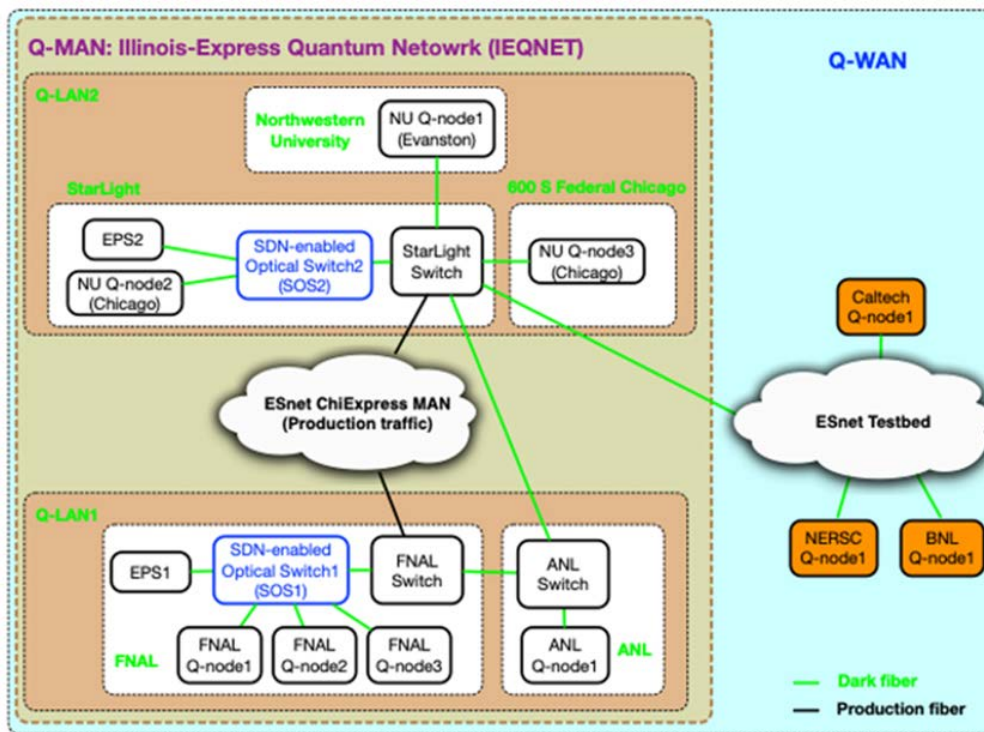

Figure 3.2. IEQNET Topology

3.3. Milestone 3: Intercity Quantum Communication using Entanglement Swapping

Quantum memory networks. In this type of quantum network, any two end users (nodes) can obtain and store entangled qubits and teleport quantum information to each other. End nodes can perform measurements and operations on the qubits they receive. The minimum memory storage requirements are determined by the time for round trip classical communications. This quantum network stage enables limited cloud quantum computing in the sense that it allows a node with the ability to prepare and measure single qubits to connect to a remote quantum computing server.

Establishing early, first-generation prototypes that allow for identifying the leading strategies and any inefficiencies to be addressed will be another mechanism to guarantee the success of an overall nationwide program. To enable a thorough evaluation of components and initial stage-wise integration testing, one or more early testbeds will be needed, forming Q-LANs.

For example, there would be considerable value in expanding on the current results gleaned from the Brookhaven Lab-SBU-ESnet collaboration, which in April 2019 achieved the longest distance entanglement distribution experi-

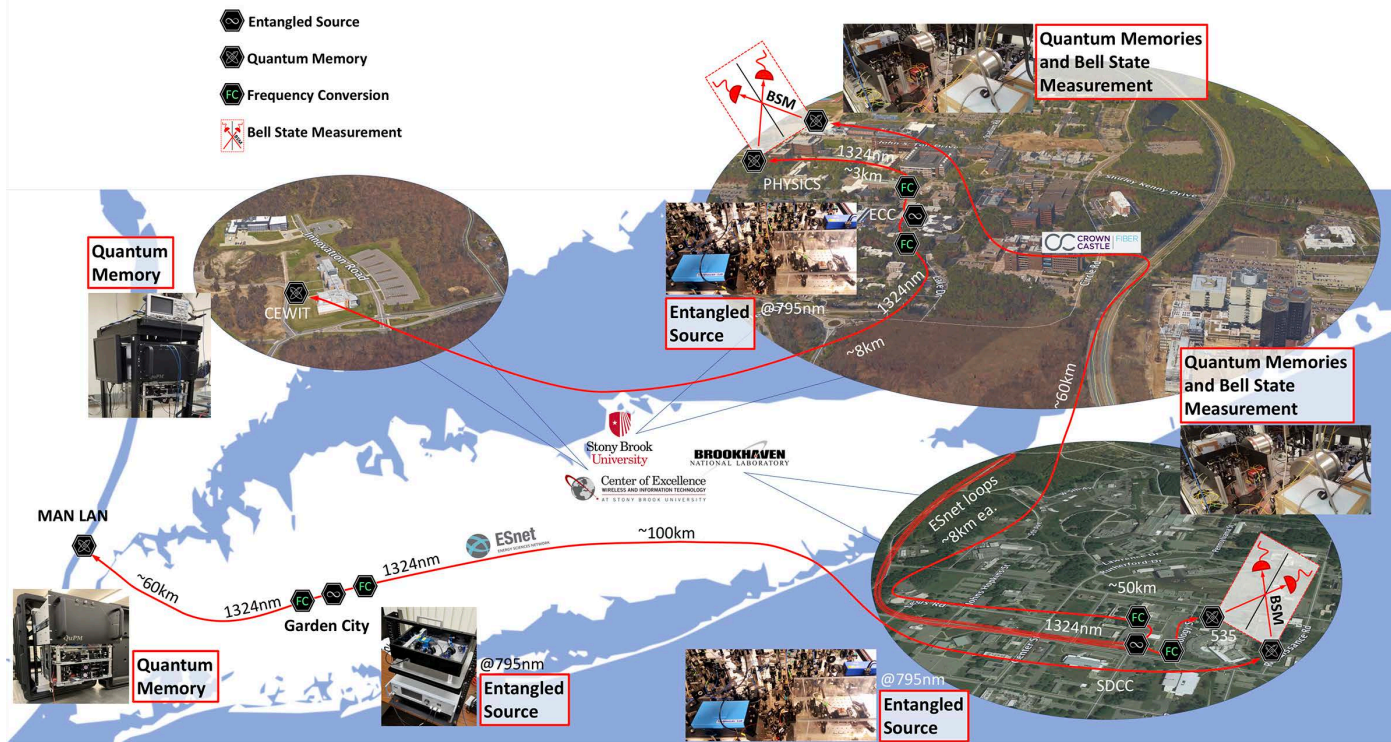

Figure 3.3: Long Island quantum network extended to New York City. The network will use a chain of quantum repeaters, extended across Long Island via three entangled sources, six quantum memories, and two entanglement swapping stations. Using ESnet’s existing fiber infrastructure, the network will connect SBU to New York City via Brookhaven Lab with intermediate stations on the two campuses and in Garden City, N.Y. This is expected to be the first quantum repeater network of its kind in the world.

ment in the United States by covering approximately 20 km. Integral to the testbed are room-temperature quantum network prototypes, developed by SBU’s Quantum Information Technology (QIT) laboratory, that connect several quantum memories and qubit sources. The combination of these important results allowed the Brookhaven–SBU–ESnet team to design and implement a quantum network prototype that connects several locations at Brookhaven Lab and SBU. By using quantum memories to enhance the swapping of the polarization entanglement of flying photon pairs, the implementation aims to distribute entanglement over long distances without detrimental losses. The team has established a quantum network on Long Island, N.Y., using ESnet’s and Crown Castle fiber infrastructure, which encompasses approximately 120-km fiber length connecting Brookhaven Lab, SBU, and Center of Excellence in Wireless and Information Technology (CEWIT) at SBU campus locations.

As a next step, the team plans to connect this existing quantum network with the Manhattan Landing (MAN-LAN) in New York City, a high-performance exchange point where several major networks converge. This work would set the stage for a nationwide quantum-protected information exchange network. Figure 3:3 depicts the planned network configuration.

3.4. Milestone 4: Interstate Quantum Entanglement Distribution using Quantum Repeater

Classic and quantum networking technologies have been integrated. Successful concatenation of quantum repeaters and quantum error-corrected communication with respect to loss and operational errors over continental-scale distances will pave the way for operational entanglement distribution networks covering longer distances, enabling a quantum Internet to be created.

Over the last year, a multi-institutional New-York-based effort led by SBU and Brookhaven Lab has explored how to design and construct the infrastructure for a first-of-its-kind quantum Internet prototype to be located across the state. Earlier, Figure 2:4 illustrated how a general approach to an extended network would be able to distribute

entangled pairs to two users at any locations. In the figure, the memories holding all of the photons involved are highlighted in light blue with the final result producing entanglement between the highlighted photons at A and B, which the users then can read out of the memories for processing.

All networks require a *management plane*, *control plane*, and *data plane*. In a quantum Internet prototype, control functions can be incorporated into an overlay network (a control plane) that interacts dynamically with the networking hardware in the quantum data plane. This control plane can be implemented using SDN architecture, which separates the control plane from the data plane. The current dominant vision for a quantum network architecture is a hop-by-hop design, where a neighboring pair of quantum communication devices performs entanglement swapping to propagate the communication channel (Kozlowski and Wehner 2019; Dahlberg et al. 2019). In this architecture, to extend the network's reach (Figure 3:4), more network repeaters must be added between the endpoints.

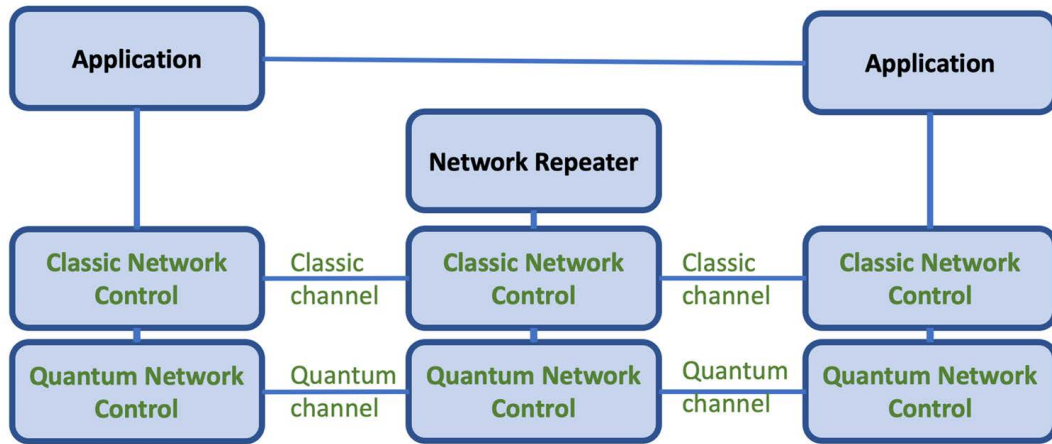

Figure 3:4. Schematic diagram of a quantum network, where quantum channels are used alongside classical communication channels.

The quantum Internet also will require a new set of protocols. While some tentative steps have been taken (Dahlberg et al. 2019; Dahlberg and Wehner 2018), a significant amount of work on communication protocols and management strategies is needed. Additional research aimed toward understanding these protocols and control strategies also will be necessary, and these efforts could use modeling and simulation as a tool to complement the theoretical work, such as in queueing theory.

A quantum Internet will not exist in isolation apart from the current classical digital networks. Quantum information largely is encoded in photons and transmitted over optical fiber infrastructure that is used widely by today's classical networks. Thus, at a fundamental level, both are supported by optical fiber that implements lightwave channels. Unlike digital information encoded and transmitted over current fiber networks, quantum information cannot be amplified with traditional mechanisms as the states will be modified if measured. While quantum networks are expected to use the optical fiber infrastructure, it could be that special fibers may enable broader deployment of this technology. At least in the near term, satellite-based entanglement "bridges" could be used to directly connect transcontinental and transatlantic Q-LANs. Preliminary estimates indicate that entangled pairs could be shared at rates exceeding 10^6 in a single pass of a Medium Earth Orbit (MEO) satellite. Such a capability may be a crucial intermediate step, while efficient robust repeaters are developed (as some estimates predict more than 100 repeaters would be needed to establish a transatlantic link).

3.5. Milestone 5: Build a Multi-institutional Ecosystem between Laboratories, Academia, and Industry to Transition from Demonstration to Operational Infrastructure

Cross-cutting. To implement this quantum communication infrastructure and actualize it into a full-fledged prototype of a quantum Internet, coordination and cooperation among federal agencies are paramount. Interaction and integration of complementary infrastructures across agencies with substantial quantum networking portfolios and those with key mission needs in this space, including DOE, NSF, National Institute for Standards and Technology, Department of Defense, National Security Agency, National Aeronautics and Space Administration (NASA), and the National Institutes of Health, are particularly relevant. While pursuing these alliances, critical opportunities for new directions and spin-off applications should be encouraged by robust cooperation with quantum communication startups and large optical communications companies. Early adopters can deliver valuable design metrics.

The following key points in quantum Internet prototype development notably could benefit from leveraging this multi-institutional ecosystem:

- Adopt concepts of management telemetry and use facilities available from global network companies.
- Leverage current ESnet optical synchronization techniques and networking to configure the higher communication levels of complex quantum networks.
- Establish schemes to buy (or rent) fiber infrastructure from commercial partners at low cost.
- Determine the fiber quality, maps, topologies, and losses of large fiber networks in partnership with fiber providers, such as ESnet, Internet2, commercial vendors, and state networks.
- Explore the feasibility of using collocation space as fiber exchange points, sponsored by commercial partners.
- Develop a "quantum-smart" workforce to support the new quantum networks with assistance from specialized startups.
- Create, in conjunction with specialized research centers and other agencies, a technological standard for quantum communication hardware that can be scaled and deployed.
- Coordinate with spatial optical and satellite-based networks that are being developed simultaneously (e.g., Air Force Research Laboratory or NASA).
- Promote adoption of first-generation quantum communication gear with large communication companies.

Workshop Report Authors

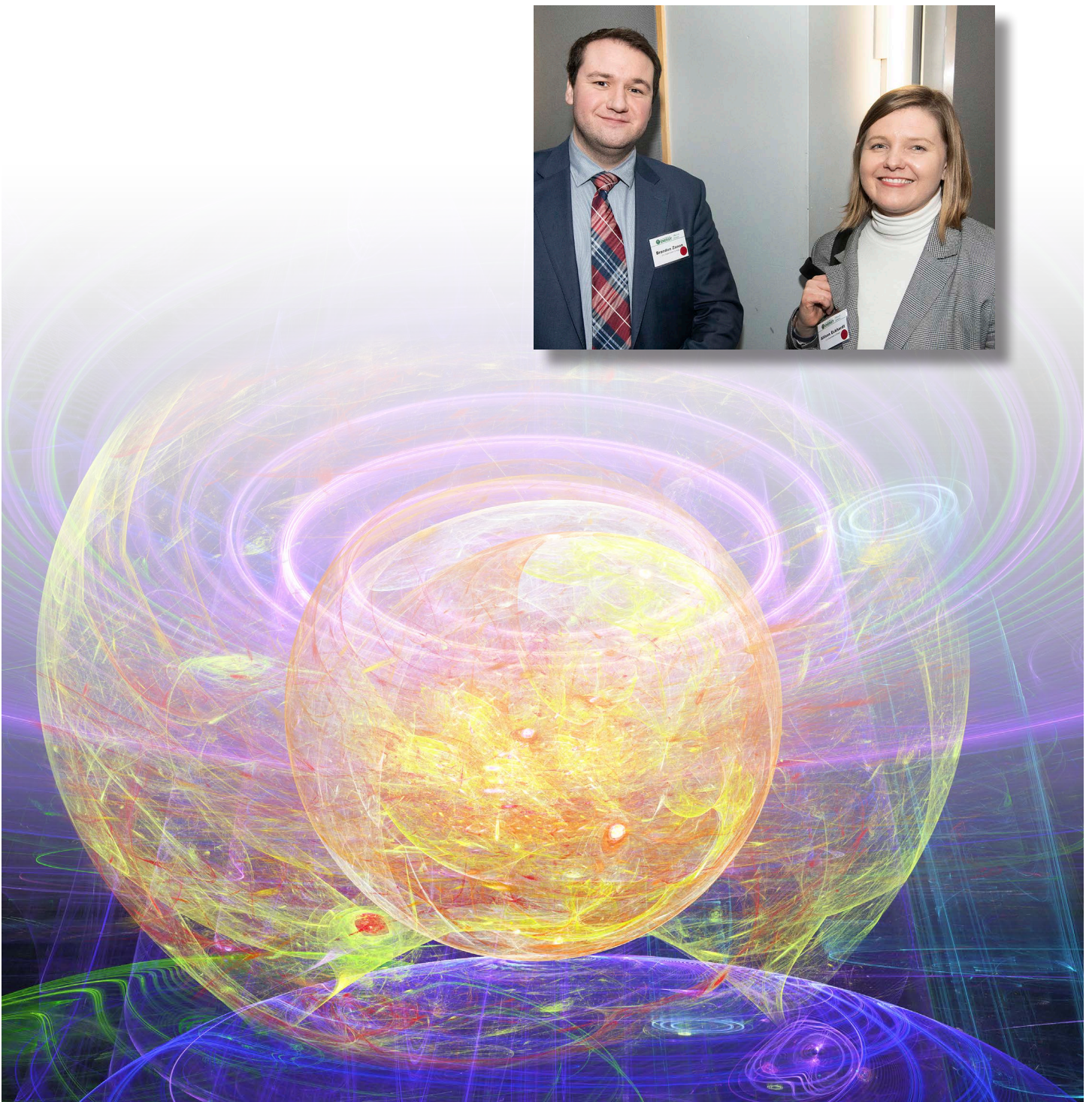

4. Workshop Report Authors

First Name	Last Name	Company Name
David	Awschalom	Argonne National Laboratory/University of Chicago
Michael	Blodgett	Energy Sciences Network
Gerald	Borsuk	U.S. Naval Research Laboratory
Gabriella	Carini	Brookhaven National Laboratory
Thomas	Chapuran	Perspecta Labs
Jerry	Chow	IBM Quantum
Paul	Dabbar	U.S. Department of Energy, Under Secretary for Science
Brig	Elliott	Self-employed
Dirk	Englund	Massachusetts Institute of Technology
Yao-Lung L.	Fang	Brookhaven National Laboratory
Fredrik	Fatemi	CCDC Army Research Laboratory
Eden	Figuroa	Stony Brook University/Brookhaven National Laboratory
Jay	Gambetta	IBM Corporation
Daniel	Gauthier	The Ohio State University
Saikat	Guha	University of Arizona
Supratik	Guha	Argonne National Laboratory
Michael	Hayduk	Air Force Research Laboratory
Tony	Heinz	Raytheon BBN Technologies
Layla	Hormozi	Brookhaven National Laboratory
Liang	Jiang	University of Chicago
Ezekiel	Johnston-Halperin	The Ohio State University
Dimitrios	Katramatos	Brookhaven National Laboratory
Kerstin	Kleese van Dam	Brookhaven National Laboratory
Hari	Krovi	Raytheon BBN Technologies
Prem	Kumar	Northwestern University
Paul	Kwiat	University of Illinois at Urbana-Champaign
John	Lekki	National Aeronautics and Space Administration/ Goddard Space Flight Center
Marko	Loncar	Harvard University
Joseph	Lukens	Oak Ridge National Laboratory
Mark	Lutwyche	University of Maryland/Laboratory for Physical Sciences
Joseph	Lykken	Fermi National Accelerator Laboratory
Xuedan	Ma	Argonne National Laboratory
Joe	Mambretti	Northwestern University/ International Center for Advanced Internet Research
Michael	McGuigan	Brookhaven National Laboratory
Inder	Monga	Energy Sciences Network/ Lawrence Berkeley National Laboratory
Raymond	Newell	Los Alamos National Laboratory
Nicholas	Peters	Oak Ridge National Laboratory
Raphael	Pooser	Oak Ridge National Laboratory
Bing	Qi	Oak Ridge National Laboratory
Nageswara	Rao	Oak Ridge National Laboratory
Michael	Raymer	University of Oregon
Tom	Reinecke	U.S. Naval Research Laboratory
Olli-Pentti	Saira	Brookhaven National Laboratory
Mark	Saffman	University of Wisconsin-Madison

Babak	Saif	National Aeronautics and Space Administration/ Goddard Space Flight Center
Thomas	Schenkel	Lawrence Berkeley National Laboratory
Oliver	Slattery	National Institute of Standards and Technology
Kathy-Anne	Soderberg	Air Force Research Laboratory
Panagiotis	Spentzouris	Fermi National Accelerator Laboratory
Maria	Spiropulu	California Institute of Technology
Paul	Stankus	Brookhaven National Laboratory
Martin	Suchara	Argonne National Laboratory
Sepehr	Taghavi	Xanadu Quantum Technologies
Hong	Tang	Yale University
Loucas	Tsakalagos	GE Research
Nick	Vamivakas	University of Rochester
Guillaume	Verdon	Alphabet X
Zachary	Vernon	Xanadu
Robert	Vietzke	University Corporation for Advanced Internet Development/Internet2
Lou	Von Thae	UT Battelle
Carl	Williams	National Institute of Standards and Technology
John	Wu	Lawrence Berkeley National Laboratory

Workshop Observers

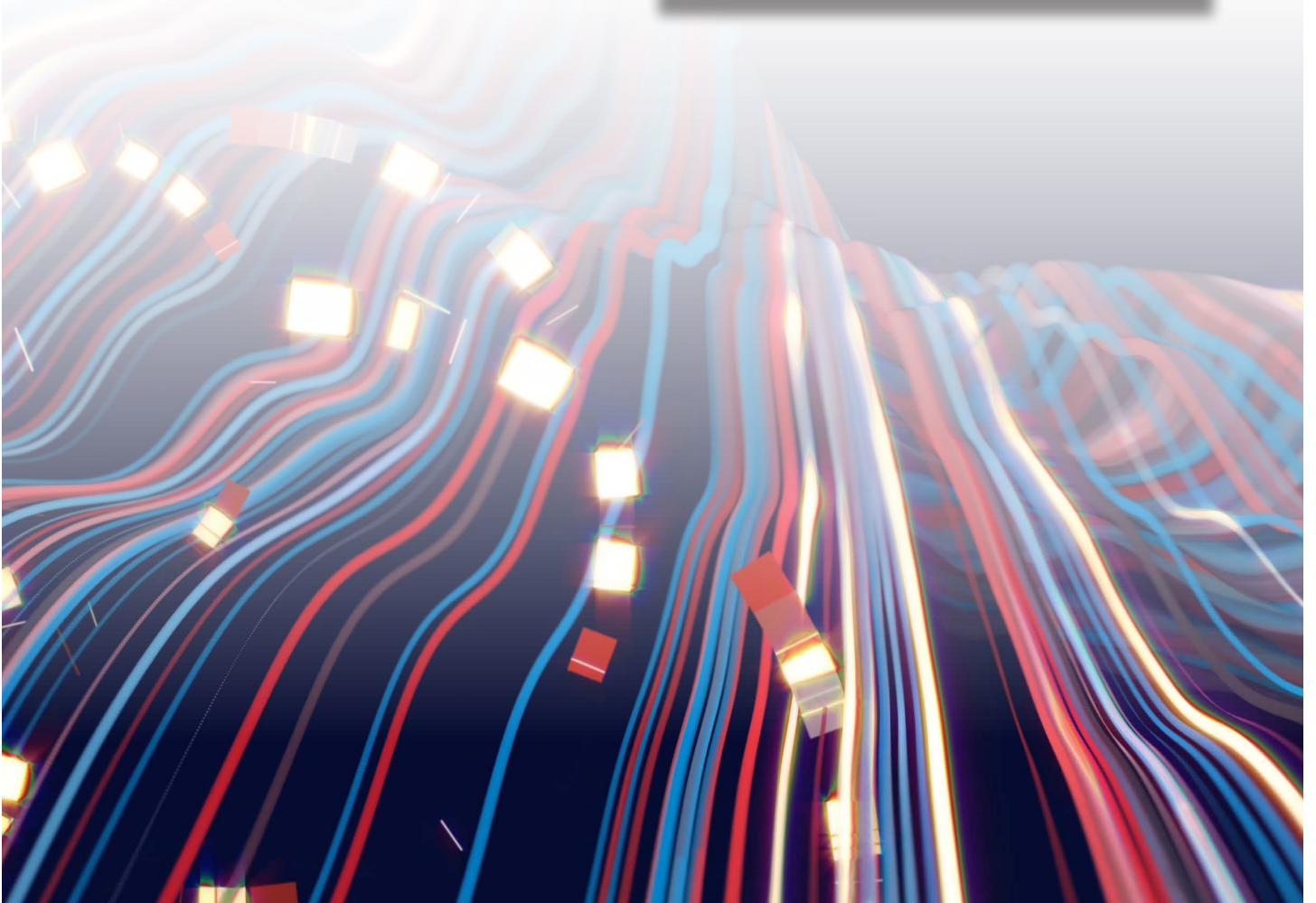

5. Workshop Observers

First Name	Last Name	Company Name
Altaf	Carim	U.S. Department of Energy/HEP
Miki	Carver	U.S. Department of Energy
Thomas	Cubbage	U.S. Department of Energy
Allison	Eckhardt	U.S. Department of Energy
Patricia	Foy	Brookhaven National Laboratory
Anthony	Giannetti	U.S. Department of Energy
Doon	Gibbs	Brookhaven National Laboratory
Carol	Hawk	U.S. Department of Energy/Office of Science ASCR
Barbara	Helland	U.S. Department of Energy
Jeremy	Ison	U.S. Department of Energy
Kristina	Johnson	State University of New York
Harriet	Kung	U.S. Department of Energy
Jim	Kyriannis	New York State Education and Research Network
Paul	Lopata	U.S. Department of Energy/Office of Secretary of Defense
Bogdan	Mihaila	National Science Foundation
Robert	Myers	U.S. Department of Energy
Rima	Oueid	U.S. Department of Energy
Conner	Prochaska	U.S. Department of Energy
Richard J.	Reeder	State University of New York, Stony Brook
Edward	Rhyné	Senior Technical Advisor of Cybersecurity for Energy Delivery Systems (CEDs)
Charles	Rousseaux	U.S. Department of Energy
Jake	Taylor	White House Office of Science and Technology Policy
Grace	Wang	State University of New York
Brandon	Zanon	U.S. Department of Energy

References



6. References

- Arute, Frank, Kunal Arya, Ryan Babbush, Dave Bacon, Joseph C. Bardin, Rami Barends, Rupak Biswas, et al. 2019. "Quantum Supremacy Using a Programmable Superconducting Processor." *Nature* 574 (7779): 505–10.
- Awschalom, David, Karl K. Berggren, Hannes Bernien, Sunil Bhave, et al., 2019. "Development of Quantum InterConnects for Next-Generation Information Technologies." arXiv:1912.06642v2. Available online: <https://arxiv.org/ftp/arxiv/papers/1912/1912.06642.pdf>.
- Brooks, Michael. 2019. "Beyond Quantum Supremacy: The Hunt for Useful Quantum Computers." *Nature* 574 (7776): 19–21.
- Dahlberg, Axel, Julio de Oliveira Filho, Ronald Hanson, Stephanie Wehner, Matthew Skrzypczyk, Tim Coopmans, Leon Wubben, et al. 2019. "A Link Layer Protocol for Quantum Networks." In *Proceedings of the ACM Special Interest Group on Data Communication – SIGCOMM '19*, 159–73. New York, New York, USA: ACM Press.
- Dahlberg, Axel, and Stephanie Wehner. 2018. "SimulaQron—a Simulator for Developing Quantum Internet Software." *Quantum Science and Technology*. <https://doi.org/10.1088/2058-9565/aad56e>.
- Fitzsimons, Joseph F. 2017. "Private Quantum Computation: An Introduction to Blind Quantum Computing and Related Protocols." *Npj Quantum Information*. <https://doi.org/10.1038/s41534-017-0025-3>.
- Hasegawa, Yasushi, Rikizo Ikuta, Nobuyuki Matsuda, Kiyoshi Tamaki, Hoi-Kwong Lo, Takashi Yamamoto, Koji Azuma, and Nobuyuki Imoto. 2019. "Experimental Time-Reversed Adaptive Bell Measurement towards All-Photonic Quantum Repeaters." *Nature Communications* 10 (1): 378.
- Hruska, Joel. 2019. "IBM Preps 53-Qubit Quantum Computer for Launch in October." *ExtremeTech*. September 20, 2019. <https://www.extremetech.com/computing/298719-ibm-preps-53-qubit-quantum-computer-for-launch-in-october>.
- Kozłowski, Wojciech, and Stephanie Wehner. 2019. "Towards Large-Scale Quantum Networks." In , Article 3.
- Krut'yanskiy, V., M. Meraner, J. Schupp, V. Krčmásky, H. Hainzer, and B. P. Lanyon. 2019. "Light-Matter Entanglement over 50 Km of Optical Fibre." *Npj Quantum Information*. <https://doi.org/10.1038/s41534-019-0186-3>.
- Messier, Doug. 2019. "China's Quantum Satellite Establishes Photon Entanglement Over 1,200 Km." *Parabolic Arc*. June 19, 2019. <http://www.parabolicarc.com/2019/06/19/china-quantum-satellite-establishes-photon-entanglement-1200-km/>.
- Moore, Samuel K. 2019. "Another Step toward the End of Moore's Law: Samsung and TSMC Move to 5-Nanometer Manufacturing - [News]." *IEEE Spectrum*. <https://doi.org/10.1109/mspec.2019.8727133>.
- Oberhaus, D. 2020. "NASA's Plan to Turn the ISS Into a Quantum Laser Lab." *Wired*, April 22, 2020. <https://www.wired.com/story/nasas-plan-to-turn-the-iss-into-a-quantum-laser-lab/>.
- Pant, Mihir, Hari Krovi, Dirk Englund, and Saikat Guha. 2017. "Rate-Distance Tradeoff and Resource Costs for All-Optical Quantum Repeaters." *Physical Review A*. <https://doi.org/10.1103/physreva.95.012304>.
- Plata, Charity. 2019. "Quantum Goes the Distance." Brookhaven National Laboratory. April 8, 2019. <https://www.bnl.gov/newsroom/news.php?a=214491>.
- Sangouard, Nicolas, Christoph Simon, Hugues de Riedmatten, and Nicolas Gisin. 2011. "Quantum Repeaters Based on Atomic Ensembles and Linear Optics." *Reviews of Modern Physics* 83 (1): 33–80.
- Simon, C. 2017. "Towards a Global Quantum Network." *Nature Photonics* 11, 678. <https://doi.org/10.1038/s41566-017-0032-0>.
- Simon, C., M. Afzelius, J. Appel, A. Boyer de la Giroday, S. J. De-whurst, N. Gisin, C. Y. Hu, et al. 2010. "Quantum Memories." *The European Physical Journal D*. <https://doi.org/10.1140/epjd/e2010-00103-y>.
- U. S. Department of Energy, Office for Advanced Scientific Computing Research. 2018. "Quantum Networks for Open Science." U. S. Department of Energy, Office for Advanced Scientific Computing Research. <https://arxiv.org/ftp/arxiv/papers/1910/1910.11658.pdf>.
- U. S. Department of Energy, Office of Basic Energy Sciences. 2017. "Opportunities for Basic Research for Next-Generation Quantum Systems." U. S. Department of Energy, Office of Basic Energy Sciences. https://science.osti.gov/-/media/bes/pdf/reports/2018/Quantum_systems.pdf?la=en&hash=291099097EBC-CFAB99D86F60F62EA061F996424C.
- Yin, Juan, Yuan Cao, Yu-Huai Li, Sheng-Kai Liao, Liang Zhang, Ji-Gang Ren, Wen-Qi Cai, et al. 2017. "Satellite-Based Entanglement Distribution over 1200 Kilometers." *Science* 356 (6343): 1140–44.
- Yin, Juan, Yuan Cao, Yu-Huai Li, Ji-Gang Ren, Sheng-Kai Liao, Liang Zhang, Wen-Qi Cai, et al. 2017. "Satellite-to-Ground Entanglement-Based Quantum Key Distribution." *Physical Review Letters* 119 (20): 200501.

This report was prepared as an account of work sponsored by an agency of the United States government. Neither the United States government nor any agency thereof, nor any of their employees, makes any warranty, express or implied, or assumes any legal liability or responsibility for the accuracy, completeness, or usefulness of any information, apparatus, product, or process disclosed, or represents that its use would not infringe privately owned rights. Reference herein to any specific commercial product, process, or service by trade name, trademark, manufacturer, or otherwise does not necessarily constitute or imply its endorsement, recommendation, or favoring by the United States government.

